

FECHE MAX-AR 725D36-12.5



CARACTERÍSTICAS

EMBALAGEM		
COMPONENTE	M. PRIMA	QTDE
FECHE	ALUMÍNIO	1
CONTRA FECHE	POLÍMERO	1
PARF W3/16X8 PAN/COMB	INOX	2

CODIFICAÇÃO

VER	COR	CÓDIGO	CATÁLOGO
DIR	BCO	9207285	FEC725D36125BCO
	BP3	9209778	FEC725D36125BP3
	PRA	9209634	FEC725D36125PRA
	PTF	9209308	FEC725D36125PTF
	TIT	9207289	FEC725D36125TIT

APLICAÇÃO

LINHA 42

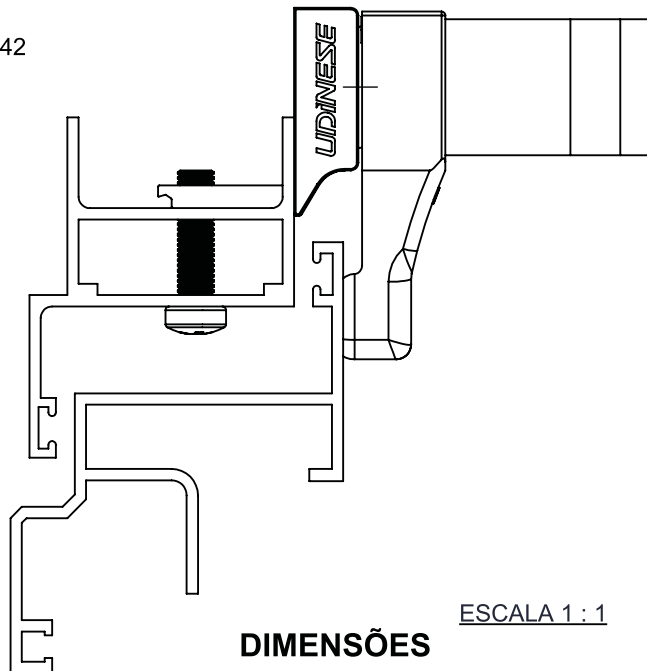

ESCALA 1 : 1

DIMENSÕES

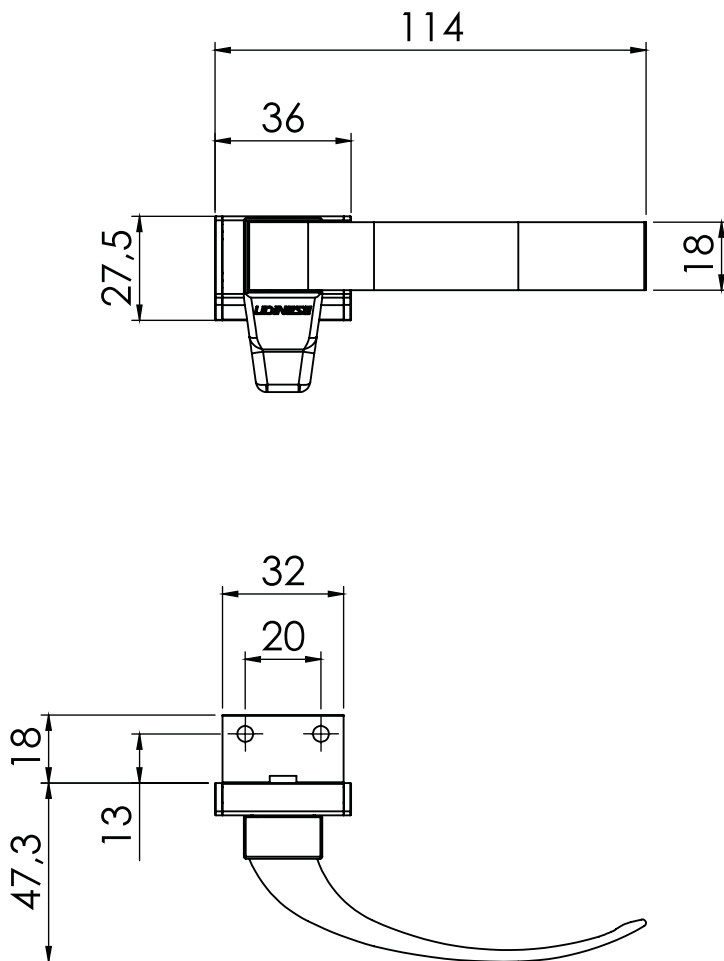

ESCALA 1 : 2

MAXIM-AR
CONVENCIONAL

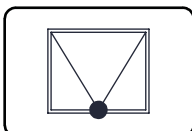

UDINESE

FECCHO MAX-AR 725D36-12.5

INSTRUÇÃO DE MONTAGEM E USINAGEM

IMAGEM MERAMENTE ILUSTRATIVA

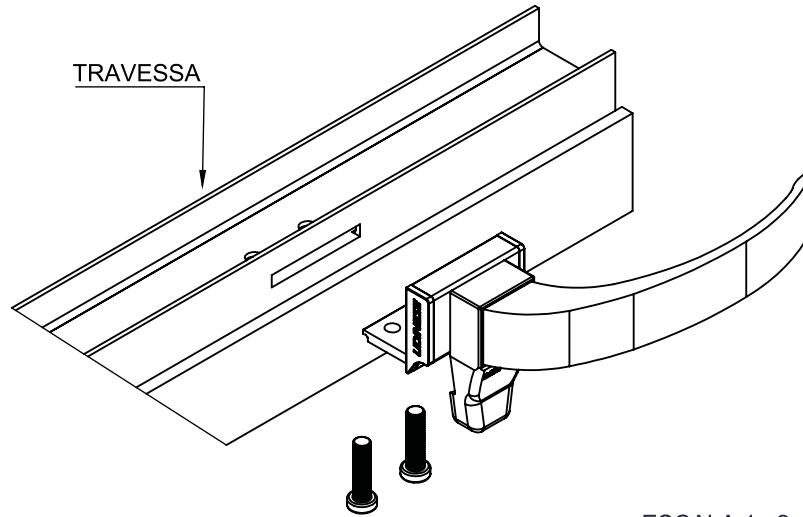

ESCALA 1 : 2

USINAGEM DA TRAVESSA

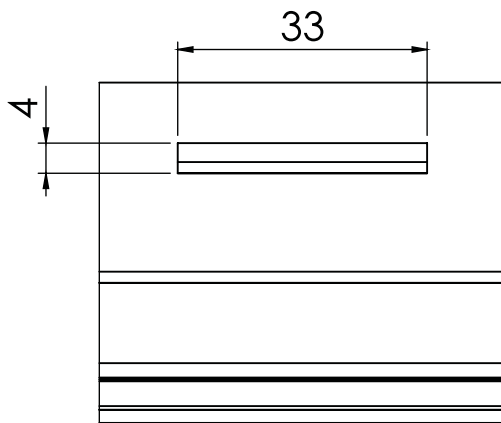

REFERÊNCIA DE USINAGEM

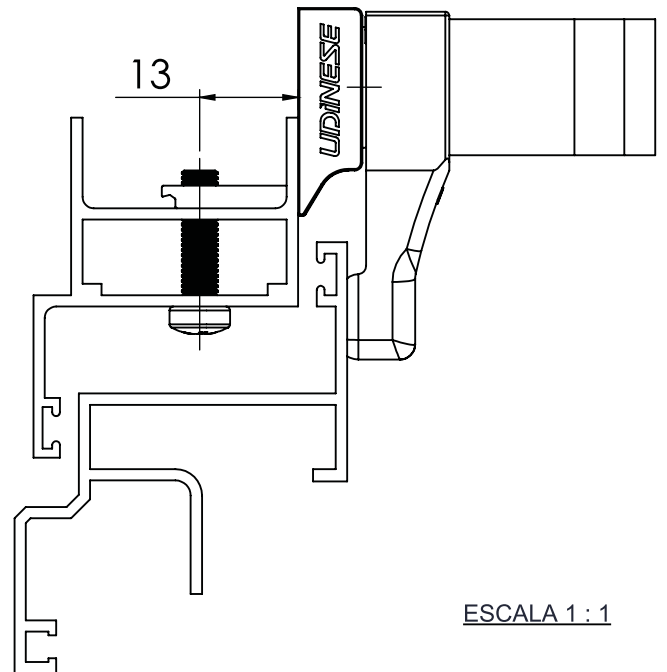

ESCALA 1 : 1

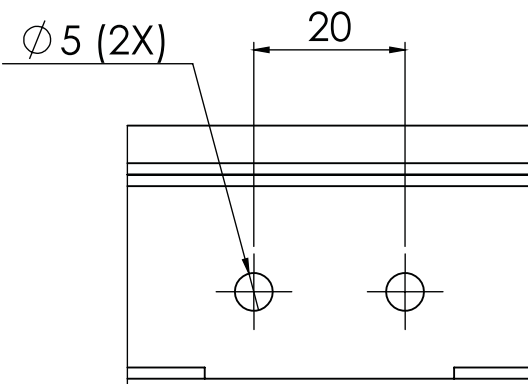

UDINESE